

## Applications

- Primary standard for defining the pressure scale in a range up to 5,000 bar
- Reference instrument for testing, adjusting and calibrating pressure measuring instruments in factories and calibration laboratories
- Self-contained, complete system also suitable for on-site measurements/calibrations

## Special features

- Total uncertainty of measurement down to 0.02 % of reading
- Factory calibration certificate as standard, traceable to National Standards, DKD/DAkks calibration certificate available as an option
- High long-term stability with a recommended recalibration cycle of 5 years
- Masses manufactured from stainless steel and aluminium, local gravity adjustment possible at no additional charge



## Description

### Proven primary standard

Pressure balances are the most accurate instruments for the calibration of electronic or mechanical pressure measuring instruments. The direct measurement of pressure, ( $P = F/A$ ) and the use of high-quality materials, result in small measurement uncertainties and an excellent long-term stability of five years (Recommendation in accordance with the German Calibration Service DKD/DAkks).

For these reasons pressure balances have already been used in the calibration laboratories of industry, national institutes and research laboratories for many years.

### Self-contained operation

Due to the integrated pressure generation and the purely mechanical measuring principle, the **CPB5000-HP** is ideally suited to on-site use as well as service and maintenance purposes.

### Basic principle

Pressure is defined as the quotient of force and area. Correspondingly, the core of the **CPB5000-HP** is a very precisely-manufactured piston cylinder system, which is loaded with masses in order to generate the individual test points.

The weight applied is proportional to the desired pressure and accomplished by using optimally graduated weights. These weights are manufactured to standard gravity (9.80665 m/s<sup>2</sup>) although, for fixed location usage, they can be adjusted to a customer-specified local gravity.

Архангельск (8182)63-90-72  
Астана (7172)727-132  
Астрахань (8512)99-46-04  
Барнаул (3852)73-04-60  
Белгород (4722)40-23-64  
Брянск (4832)59-03-52  
Владивосток (423)249-28-31  
Волгоград (844)278-03-48  
Вологда (8172)26-41-59  
Воронеж (473)204-51-73  
Екатеринбург (343)384-55-89  
Иваново (4932)77-34-06

Ижевск (3412)26-03-58  
Иркутск (395)279-98-46  
Казань (843)206-01-48  
Калининград (4012)72-03-81  
Калуга (4842)92-23-67  
Кемерово (3842)65-04-62  
Киров (8332)68-02-04  
Краснодар (861)203-40-90  
Красноярск (391)204-63-61  
Курск (4712)77-13-04  
Липецк (4742)52-20-81

Магнитогорск (3519)55-03-13  
Москва (495)268-04-70  
Мурманск (8152)59-64-93  
Набережные Челны (8552)20-53-41  
Нижний Новгород (831)429-08-12  
Новокузнецк (3843)20-46-81  
Новосибирск (383)227-86-73  
Омск (3812)21-46-40  
Орел (4862)44-53-42  
Оренбург (3532)37-68-04  
Пенза (8412)22-31-16

Пермь (342)205-81-47  
Ростов-на-Дону (863)308-18-15  
Рязань (4912)46-61-64  
Самара (846)206-03-16  
Санкт-Петербург (812)309-46-40  
Саратов (845)249-38-78  
Севастополь (8692)22-31-93  
Симферополь (3652)67-13-56  
Смоленск (4812)29-41-54  
Сочи (862)225-72-31  
Ставрополь (8652)20-65-13

Сургут (3462)77-98-35  
Тверь (4822)63-31-35  
Томск (3822)98-41-53  
Тула (4872)74-02-29  
Тюмень (3452)66-21-18  
Ульяновск (8422)24-23-59  
Уфа (347)229-48-12  
Хабаровск (4212)92-98-04  
Челябинск (351)202-03-61  
Череповец (8202)49-02-64  
Ярославль (4852)69-52-93

Киргизия (996)312-96-26-47

Россия (495)268-04-70

Казахстан (772)734-952-31

# CPB5000-HP Deadweight Tester / Pressure Balance

High pressure up to 5,000 bar / 70,000 psi

LR-Cal



## Easy operation

The pressure is set via an integrated pump. For fine adjustment a very precisely adjustable spindle pump with a precision spindle running only within the pump body is mounted. As soon as the measuring system reaches equilibrium, there is a balance of forces between pressure and mass applied. The excellent quality of the system ensures that this pressure remains stable over several minutes, so that the device under test can be calibrated or time-consuming adjustments can be carried out without any problems.

## Solid instrument design

With the highpressure model calibrations up to a maximum pressure of 5,000 bar / 70,000 psi are possible. It has been designed around a solid platform and offers exceptional ease-of-use. With the integrated initial pressure pump and the 250 ml tank, large test volumes can also be easily filled and pre-compressed.

The piston cylinder system is fixed to the basement and has special bearings ensuring excellent operating characteristics with a long free rotation time and low fall rates and a very high long-term stability also at high pressures and forces. Therefore the recommended recalibration interval is 5 years.

The materials of the piston and cylinder have very small pressure and thermal expansion coefficients, which results in a very good linearity of the effective cross-sectional area of the piston and high measurement accuracy.

The test connection is equipped with a knurled nut and interchangeable threaded adapters with metal sealing cones. M16 x 1.5, M20 x 1.5 and 9/16-18 UNF adapters are in scope of supply.

## Tables of masses

The following tables show the number of weights per measuring range, within a weight set, with their nominal mass values and the resulting nominal pressures. Should you not operate the device under reference conditions (ambient temperature 20 °C, air pressure 1013 mbar, relative humidity 40 %), corrections must be considered, if necessary.

These weights are manufactured to standard gravity (9.80665 m/s<sup>2</sup>) although, for fixed location usage, they can be adjusted to a customer-specified local gravity.

Measuring range [bar]	25 ... 2,500		25 ... 4,000		25 ... 5,000	
	Pieces	Nominal pressure per piece	Pieces	Nominal pressure per piece	Pieces	Nominal pressure per piece
		bar		bar		bar
Piston incl. bell jar	1	25	1	25	1	25
Masses 5 kg	-	-	6	250	10	250
Masses 4 kg	8	200	8	200	8	200
Masses 2 kg	9	100	9	100	9	100
Masses 1 kg	1	50	1	50	1	50
Masses 0.5 kg	2	25	2	25	2	25
Masses 0.2 kg	1	10	1	10	1	10
Masses 0.1 kg	1	5	1	5	1	5
Masses 0.05 kg	1	2.5	1	2.5	1	2.5

Measuring range [psi]	350 ... 40,000		350 ... 60,000		350 ... 70,000	
	Pieces	Nominal pressure per piece	Pieces	Nominal pressure per piece	Pieces	Nominal pressure per piece
		psi		psi		psi
Piston incl. bell jar	1	350	1	350	1	350
Masses 7 kg	2	5,000	6	5,000	8	5,000
Masses 3.5 kg	8	2,500	8	2,500	8	2,500
Masses 1.4 kg	8	1,000	8	1,000	8	1,000
Masses 1 kg	1	750	1	750	1	750
Masses 0.7 kg	2	500	2	500	2	500
Masses 0.35 kg	1	250	1	250	1	250
Masses 0.14 kg	1	100	1	100	1	100
Masses 0.07 kg	1	50	1	50	1	50

Specifications		Type CPB5000-HP		
Measuring range	bar <sup>1)</sup>	25 ... 2,500	25 ... 4,000	25 ... 5,000
Required weights	kg	50	80	100
Smallest step	bar <sup>2)</sup>	2.5	2.5	2.5
Nominal cross-sectional area of the piston	cm <sup>2</sup>	0.02	0.02	0.02
Measuring range	psi <sup>1)</sup>	350 ... 40,000	350 ... 60,000	350 ... 70,000
Required weights	kg	55	83	97
Smallest step	psi <sup>2)</sup>	50	50	50
Nominal cross-sectional area of the piston	cm <sup>2</sup>	0.02	0.02	0.02
Accuracy <sup>3)</sup>	% of reading	0.025 / optional: 0.02 <sup>4)</sup>		
Pressure transmission medium		up to 4,000 bar/60,000 psi: mineral oil based hydraulic fluid (1 litre is included in delivery) 5,000 bar/70,000 psi: Sebacate-oil (0.5 litre is included in delivery)		
Oil reservoir	cm <sup>3</sup>	250		
Connection for the test specimen		test specimen can be freely positioned, 3 threaded adapters as standard M16 x 1.5 / M20 x 1.5 and 9/16-18UNF for other threaded adapters, see accessories		
Material				
■ Piston		hardened steel		
■ Cylinder		tungsten carbide		
■ Mass-set		stainless steel 1.4305 and aluminium, non-magnetic		
■ Piping in instrument base		stainless steel 1.4404, 6 x 2 mm		
Operating temperature	°C	18 ... 28		
Weight				
■ Instrument base, high pressure	kg	32.5		
■ Piston cylinder system	kg	2.7 / 5.0 (incl. storage suit case)		
■ BAR basic mass-set, part 1	kg	34.0 (incl. carrying case)		
■ BAR basic mass-set, part 2	kg	27.5 (incl. carrying case)		
■ BAR mass-set extension, part 1 (for 4,000 bar and 5,000 bar)	kg	33.5 (incl. carrying case)		
■ BAR mass-set extension, part 2 (only for 5,000 bar)	kg	23.5 (incl. carrying case)		
Weight				
■ PSI basic mass-set, part 1	kg	51.0 (incl. carrying case)		
■ PSI basic mass-set, part 2	kg	15.0 (incl. carrying case)		
■ PSI mass-set extension, part 1 (for 60,000 psi and 70,000 psi)	kg	31.8 (incl. carrying case)		
■ PSI mass-set extension, part 2 (only for 70,000 psi)	kg	17.8 (incl. carrying case)		
Dimensions				
■ Instrument base	mm	460 (W) x 445 (D) x 265 (H), for details see technical drawing		
■ Carrying case for basic mass-set, part 1	mm	400 (W) x 310 (D) x 310 (H)		
■ Carrying case for basic mass-set, part 2	mm	215 (W) x 310 (D) x 310 (H)		
■ Carrying case for mass-set extension	mm	215 (W) x 310 (D) x 310 (H)		
■ Carrying case for piston cylinder system	mm	370 (W) x 150 (D) x 150 (H)		
CE-conformity				
■ Pressure equipment directive		97/23/EG (Module A)		
Calibration		Factory calibration certificate (optional: DKD/DAkkS calibration certificate)		

1) Theoretical starting value; corresponds to the pressure value generated by the piston (by its own weight). To optimise the operating characteristics more weights should be loaded.

2) The lowest pressure change value that is reached based on the standard weight set. A fine weight set is also available for lower values.

3) The accuracy is in reference to the measurement value, from 10 % of the measurement range. A fixed error is considered in the lower area in reference to 10 % of the area.

4) Measurement uncertainty assuming reference conditions (room temperature 20 °C, air pressure 1013 mbar, relative humidity 40 %). Corrections may be required for use without CalibratorUnit.

# CPB5000-HP Deadweight Tester / Pressure Balance

High pressure up to 5,000 bar / 70,000 psi

LR-Cal



## Dimensions in mm

Front view

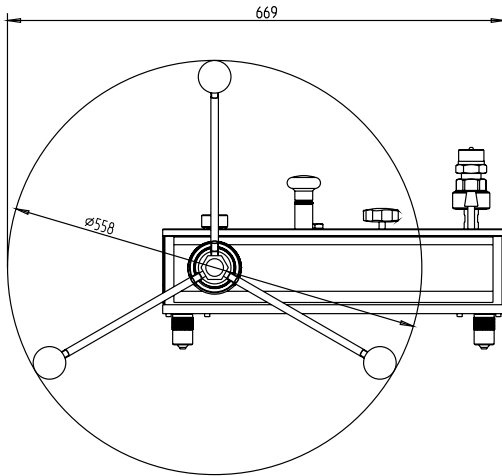

Side view

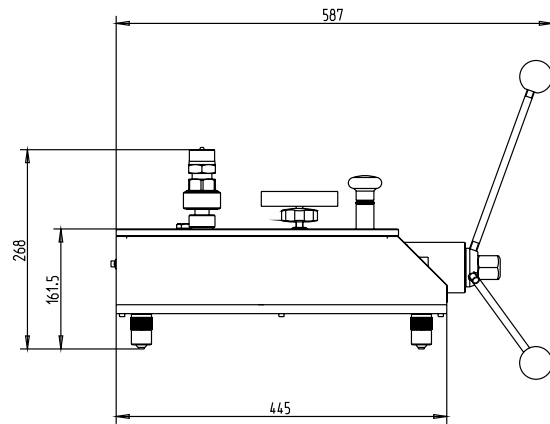

Plan view

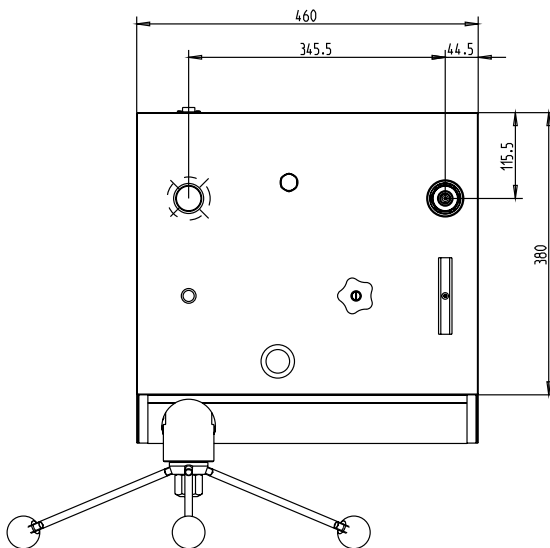

Connection for the test item

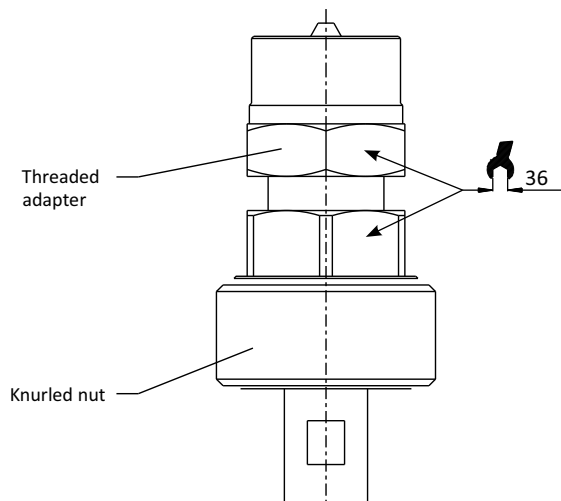

## Scope of supply

- Instrument base with dust cover
- Initial pressure pump
- Spindle pump for pressure generation/fine adjustment
- Connection for piston cylinder system
- Connection for test devices with 3 threaded adapters M16 x 1.5 / M20 x 1.5 and 9/16-18 UNF
- Piston cylinder system with bell jar
- Basic mass set divided into 2 carrying cases
- Mass-set extension in 1 carrying case (for 4,000 bar or 60,000 psi resp. in 2 carrying cases for 5,000 bar or 70,000 psi)
- Mass-set manufactured to standard gravity (9.80665 m/s<sup>2</sup>)
- Operating fluid 1.0 litre (up to 4,000 bar/60,000 psi)
- Operating fluid 0.5 litre (for 5,000 bar/70,000psi)

- Wrenches 36 flats and 46 flats
- Operating instructions in German and English
- Factory calibration certificate

## Options

- Systems with increased accuracy to 0.02 %
- Mass-set manufactured to local gravity
- DKD/DAkkS calibration certificate

### Further LR-Cal Deadweight Tester / Pressure Balances:

#### Model LR-Cal LDW-P

Pneumatic

Ranges from -0.03...-1 to +0.4...+100 bar  
from -0.435...-14 to +5.8...+1,500 psi

Accuracy  $\pm 0.015\%$  or  $\pm 0.008\%$  of measured value



#### Model LR-Cal LDW-HK

Hydraulic (compact design)

Ranges from 1...120 to 10...1,200 bar  
from 10...1,600 to 100...16,000 psi

Accuracy  $\pm 0.05\%$  or  $\pm 0.025\%$  of measured value



#### Model LR-Cal LDW-H

Hydraulic

Single Piston

Ranges from 1...120 to 2...300 bar  
from 10...1,600 to 30...4,000 psi

Double Piston

Ranges from 1...60 / 10...700 bar to  
1...60 / 20...1,400 bar  
from 10...800 / 100...10,000 psi to  
10...800 / 200...20,000 psi

Accuracy  $\pm 0.015\%$  or  $\pm 0.006\%$  of measured value



#### Modell LR-Cal CPB5600-DP

Differential pressure, pneumatic

Ranges from 0.03...2 to 0.4...100 bar  
from 0.435...30 to 5.8...1500 psi

Differential pressure, hydraulic

Ranges from 0.2...60 to 2...1,000 bar  
from 2.9...1,000 to 29...14,500 psi

Accuracy  $\pm 0.015\%$  or  $\pm 0.008\%$  of measured value



Архангельск (8182)63-90-72  
Астана (7172)727-132  
Астрахань (8512)99-46-04  
Барнаул (3852)73-04-60  
Белгород (4722)40-23-64  
Брянск (4832)59-03-52  
Владивосток (423)249-28-31  
Волгоград (844)278-03-48  
Вологда (8172)26-41-59  
Воронеж (473)204-51-73  
Екатеринбург (343)384-55-89  
Иваново (4932)77-34-06

Ижевск (3412)26-03-58  
Иркутск (395)279-98-46  
Казань (843)206-01-48  
Калининград (4012)72-03-81  
Калуга (4842)92-23-67  
Кемерово (3842)65-04-62  
Киров (8332)68-02-04  
Краснодар (861)203-40-90  
Красноярск (391)204-63-61  
Курск (4712)77-13-04  
Липецк (4742)52-20-81

Киргизия (996)312-96-26-47

Магнитогорск (3519)55-03-13  
Москва (495)268-04-70  
Мурманск (8152)59-64-93  
Набережные Челны (8552)20-53-41  
Нижний Новгород (831)429-08-12  
Новокузнецк (3843)20-46-81  
Новосибирск (383)227-86-73  
Омск (3812)21-46-40  
Орел (4862)44-53-42  
Оренбург (3532)37-68-04  
Пенза (8412)22-31-16

Россия (495)268-04-70

Пермь (342)205-81-47  
Ростов-на-Дону (863)308-18-15  
Рязань (4912)46-61-64  
Самара (846)206-03-16  
Санкт-Петербург (812)309-46-40  
Саратов (845)249-38-78  
Севастополь (8692)22-31-93  
Симферополь (3652)67-13-56  
Смоленск (4812)29-41-54  
Сочи (862)225-72-31  
Ставрополь (8652)20-65-13

Казахстан (772)734-952-31

Сургут (3462)77-98-35  
Тверь (4822)63-31-35  
Томск (3822)98-41-53  
Тула (4872)74-02-29  
Тюмень (3452)66-21-18  
Ульяновск (8422)24-23-59  
Уфа (347)229-48-12  
Хабаровск (4212)92-98-04  
Челябинск (351)202-03-61  
Череповец (8202)49-02-64  
Ярославль (4852)69-52-93