

Applications:

- Primary standard for defining the pressure scale in a range up to 100 bar, pneumatic.
- Reference instrument for testing, adjusting and calibrating pressure measuring instruments in factories and calibration laboratories.
- Self-contained, complete system also suitable for on-site measurements/calibrations.

Special features:

- Total uncertainty of measurement down to $\pm 0.008\%$ of reading.
- Factory calibration certificate as standard, traceable to National Standards, DKD-/DAkkS calibration certificate available as an option.
- High long-term stability with a recommended recalibration cycle of 5 years.
- Masses manufactured from stainless steel and aluminium, local gravity adjustment possible at not additional charge.
- Optional a quick-change system for piston-cylinder unit available, enables fast and secure exchange of the piston-cylinder system in order to change the measuring range.

**Description:****Proven primary standard**

Pressure balances are the most accurate instruments for the calibration of electronic or mechanical pressure measuring instruments. The direct measurement of pressure ($P = F/A$) and the use of high-quality materials, result in small measurement uncertainties and an excellent long-term stability of five years (Recommendation in accordance with the German Calibration Service DKD/DAkkS). For these reasons pressure balances / deadweight testers have already been used in the calibration laboratories of industry, national institutes and research laboratories for many years.

Self-contained operation

Due to the integrated pressure generation (for ranges up to 10 bar) and the purely mechanical measuring principle, the LR-Cal LDW-P deadweight tester is ideally suited to on-site use as well as service and maintenance purposes.

Basic principle

Pressure is defined as the quotient of force and area. Correspondingly, the core of the LR-Cal LDW-P deadweight tester is a very precisely-manufactured piston-cylinder system, which is loaded with masses in order to generate the individual test points.

The weight applied is proportional to the desired pressure and accomplished by using optimally graduated weights. These weights are manufactured to standard gravity (9.80665 m/s^2) although, for fixed location usage, they can be adjusted to a customer-specified local gravity.

Архангельск (8182)63-90-72
Астана (7172)727-132
Астрахань (8512)99-46-04
Барнаул (3852)73-04-60
Белгород (4722)40-23-64
Брянск (4832)59-03-52
Владивосток (423)249-28-31
Волгоград (844)278-03-48
Вологда (8172)26-41-59
Воронеж (473)204-51-73
Екатеринбург (343)384-55-89
Иваново (4932)77-34-06

Ижевск (3412)26-03-58
Иркутск (395)279-98-46
Казань (843)206-01-48
Калининград (4012)72-03-81
Калуга (4842)92-23-67
Кемерово (3842)65-04-62
Киров (8332)68-02-04
Краснодар (861)203-40-90
Красноярск (391)204-63-61
Курск (4712)77-13-04
Липецк (4742)52-20-81

Киргизия (996)312-96-26-47

Магнитогорск (3519)55-03-13
Москва (495)268-04-70
Мурманск (8152)59-64-93
Набережные Челны (8552)20-53-41
Нижний Новгород (831)429-08-12
Новокузнецк (3843)20-46-81
Новосибирск (383)227-86-73
Омск (3812)21-46-40
Орел (4862)44-53-42
Оренбург (3532)37-68-04
Пенза (8412)22-31-16

Россия (495)268-04-70

Пермь (342)205-81-47
Ростов-на-Дону (863)308-18-15
Рязань (4912)46-61-64
Самара (846)206-03-16
Санкт-Петербург (812)309-46-40
Саратов (845)249-38-78
Севастополь (8692)22-31-93
Симферополь (3652)67-13-56
Смоленск (4812)29-41-54
Сочи (862)225-72-31
Ставрополь (8652)20-65-13

Казахстан (772)734-952-31

Сургут (3462)77-98-35
Тверь (4822)63-31-35
Томск (3822)98-41-53
Тула (4872)74-02-29
Тюмень (3452)66-21-18
Ульяновск (8422)24-23-59
Уфа (347)229-48-12
Хабаровск (4212)92-98-04
Челябинск (351)202-03-61
Череповец (8202)49-02-64
Ярославль (4852)69-52-93

Easy operation

Depending on the instrument range the pressure is set via an integrated pump or via an external pressure supply by the use of control valves. For fine adjustment a very precisely adjustable spindle pump with a precision spindle running only within the pump body is mounted.

Piston-cylinder system

Both the piston and cylinder are manufactured from Tungsten Carbide. Compared to other materials, Tungsten Carbide has very small pressure and thermal expansion coefficients, which results in a very good linearity of the effective cross-sectional area of the piston and high measurement accuracy.

Piston and cylinder are very well protected in a solid stainless steel housing, against contact, impacts or contamination from outside. In addition, overpressure protection is integrated, which prevents the piston from being forced out vertically and avoids damage to the piston cylinder system in the event of weight removal under pressure.

The weight discs are stacked on a bell jar which is fitted to the piston skirt. Due to the construction of the bell jar, the centre of gravity for the stacked weights is very low, which minimises both the side thrust on the piston-cylinder system and the friction. For relatively low starting pressures, a lighter aluminium plate can be used instead of the bell jar.

The overall design of the piston-cylinder unit and the very precise manufacturing of both the piston and the cylinder ensure excellent operating characteristics with a long free-rotation time, low sink rates and a very high long-term stability. Therefore the recommended recalibration interval is 5 years.

The standard connection for the piston-cylinder system is an M30 x 2 male thread. A quick-connect system, for easy measuring range changes without tools, is available as an option.

As soon as the measuring system reaches equilibrium, there is a balance of forces between pressure and mass applied. The excellent quality of the system ensures that this pressure remains stable over several minutes, so that the device under test can be calibrated or time-consuming adjustments can be carried out without any problems.

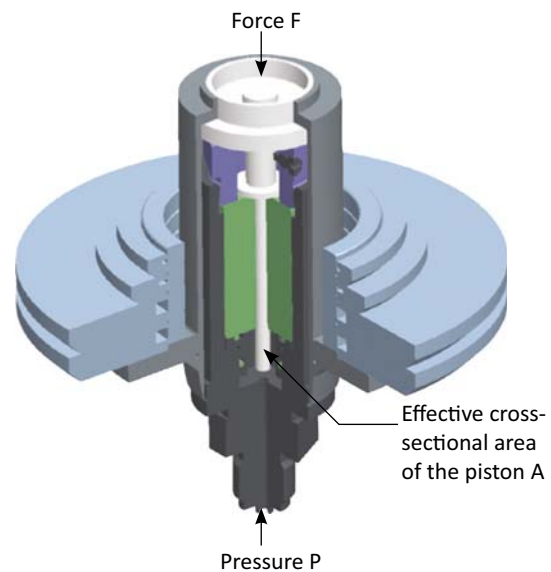
**High performance instrument base LR-Cal LDW-P**

The instrument base is supplied in two different versions, depending on the measurement range of the deadweight tester:

- Basement for ranges up to 10 bar / 150 psi
With integrated pressure generation through inlet pressure pump and spindle pump
- Basement for Vacuum and ranges ≥ 20 bar up to 100 bar / 1500 psi
With connection for external pressure supply or vacuum, incl. inlet vent.

Specifications LR-Cal LDW-P

Measuring range	bar 1)	-0,03...-1	0,03...2	0,2...10	0,4...50	0,4...100	
Required weights	kg	5	10	10	10	20	
Smallest step	bar 2)	0.01	0.01	0.05	0.25	0.25	
Nominal cross-sectional area of the piston	cm ²	5	5	1	0.2	0.2	
Measuring range	psi 1)	-0,435...-14	0,435...30	2,9...150	5,8...500	5,8...1000	5,8...1500
Required weights	kg	5	10	10	7	13	20
Smallest step	psi 2)	0.1	0.2	1	5	5	5
Nominal cross-sectional area of the piston	cm ²	5	5	1	0.2	0.2	0.2
Accuracy 3)	% MV.	0,015 / optional: 0,008 (% of measured value)					
Version							
for ranges up to 10 bar	with integrated pressure generation, ranges up to 10 bar						
for ranges above 10 bar	for external pressure source, ranges above 10 bar, and Vacuum						
Connections / Media							
Connection piston-cylinder unit	M30 x 2 male thread / optional: Quick-connector						
Pressure port for test item	Quick-fit 1/2" BSP female rotating, inserts changeable						
Pressure transmission medium	clean dry non-corrosive gases (e.g. air or nitrogen)						
External pressure port	6 mm SWAGELOK® tube fitting, max. 110% of the assigned measuring range; only for version "external pressure source" and Vacuum						
Material							
Piston	Tungsten Carbide						
Cylinder	Tungsten Carbide						
Weight set (masses)	Stainless steel 1.4305 and aluminium, non-magnetic						
Piping in instrument base	Version "integr. pressure gen.": Polyurethane hose 4 x 0.75 mm Version "for extern. pressure source": Stainless steel 1.4571, 3 x 1 mm						
Operating condition							
Operating temperature	°C	18...28					
Weight							
Base unit		18,0 (19,0 with optional quick-connector)					
Piston-cylinder system	kg	1,5 (5,7 incl. bell jar and alu.plate, in optional carrying case)					
BAR vacuum mass set	kg	13,1 (incl. piston-cylinder unit in carrying case)					
BAR basic mass set	kg	16,2 (incl. carrying case)					
BAR mass set extension	kg	14,0 (incl. carrying case)					
PSI vacuum mass set	kg	13,0 (incl. piston-cylinder unit in carrying case)					
PSI basic mass set	kg	12,5 (incl. carrying case)					
PSI mass set extension 1	kg	11,0 (incl. carrying case)					
PSI mass set extension 2	kg	18,5 (incl. carrying case) only for range 1.500 psi					
Dimension							
Base unit	mm	W 400 x D 375 x H 265					
Carrying case for basic mass set	mm	W 400 x D 310 x H 310					
Carrying case for mass set extension	mm	W 215 x D 310 x H 310					
Optional carrying case for piston-cylinder unit	mm	W 300 x D 265 x H 205					
Certificate							
Calibration	Factory certificate, traceable (Optional: DKD/DAkS certification)						

- 1) Theoretical starting value; corresponds to the pressure value generated by the piston (by its own weight). To optimise the operating characteristics more weights should be loaded.
- 2) The lowest pressure change value that is reached based on the standard weight set. A fine weight set is also available for lower values.
- 3) The accuracy is in reference to the measurement value, from 10% of the measurement range. A fixed error is considered in the lower area in reference to 10% of the area.
- 4) Measurement uncertainty assuming reference conditions (room temperature 20°C, air pressure 1013 mbar, relative humidity 40%). Corrections may be required.

Dimensions (mm) LR-Cal LDW-P

The drawing shows a base version **LR-Cal LDW-P** for external power supply (vacuum range or pressure ranges >10 bar), with optional quick-connect for the piston-cylinder system. The version with integrated pressure generation differs only in the arrangement of the control elements, and not dimensionally.

Front view

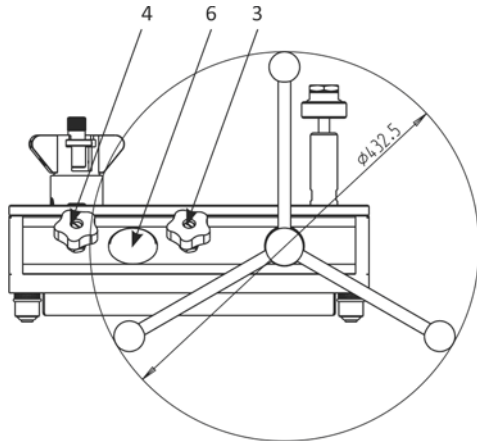

Side view

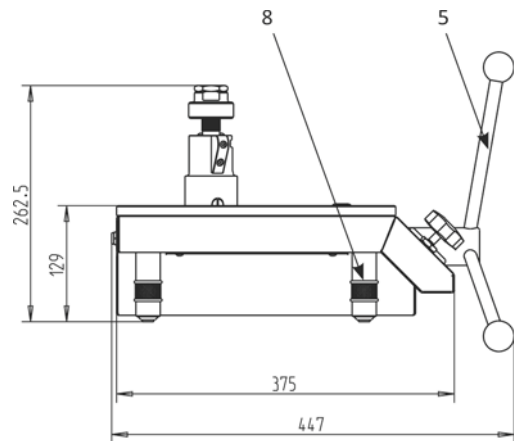

Plan view

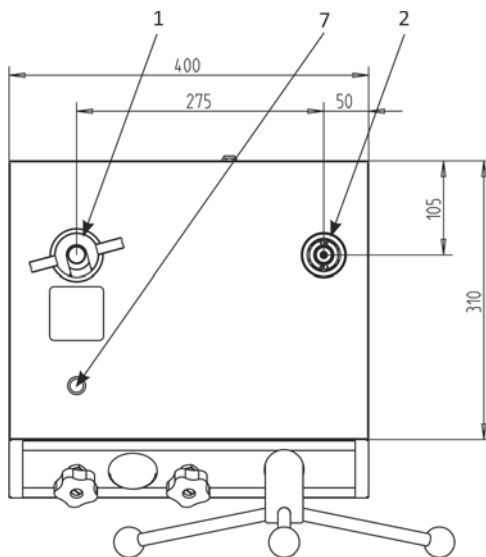

Connection for the test item

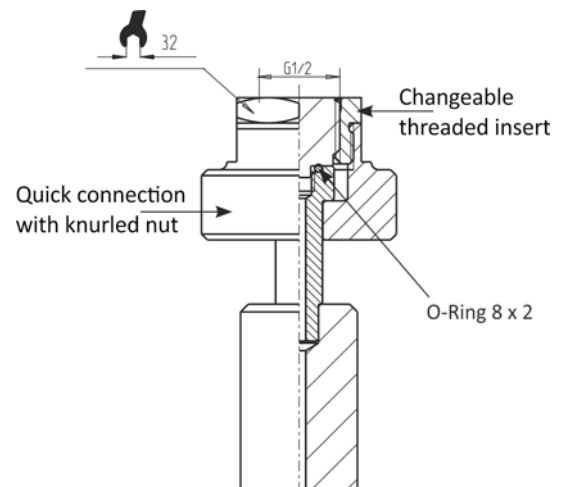

Ausführung (bis 10 bar) mit integrierter Druckversorgung
Ansicht von oben

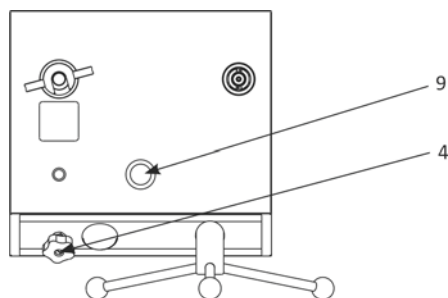

- (1) Adapter piston-cylinder system
- (2) Adapter test item
- (3) Inlet-valve (only version for external power supply)
- (4) Outlet-valve
- (5) Spindle pump with star handle, removable
- (6) Analogue pressure gauge (for visual control purposes)
- (7) Water level (for adjusting the basement)
- (8) Rotating feet (for adjusting the basement)
- (9) Priming pump (only version with integr. pressure gener.)

Scope of supply

- Instrument base with adjustable feet
- Priming pump (only versions max. 10 bar)
- Pressure input for external pressure source (only versions > 10 bar)
- Spindle pump for pressure generation / fine adjustment
- Piston adapter with M30 x 2 female thread
- Piston-cylinder system with bell jar
- Basic mass set in wooden carrying case
- Mass set extension in wooden carrying case (if required for pressure range)
- Mass set manufactured to standard gravity (9.80665 m/s²)
- Operating manual in German and English
- Factory calibration certificate

Options

- Systems with increased accuracy to 0.008%
- Piston adapter with quick-connect
- Storage suit case for piston-cylinder systems
- Mass set manufactured to local gravity
- DKD/DAkkS calibration certificate

Accessories

Trim-mass sets M1 and F1

The weights included in the **LR-Cal LDW-H** standard mass set or fine increment weights are ideally suited for everyday use. If smaller intermediate values need to be generated, we recommend using a set of class M1 or F1 trim masses, with the following weights.

1 x 50 g, 2 x 20 g, 1 x 10 g, 1 x 5 g, 2 x 2 g, 1 x 1 g,
1 x 500 mg, 2 x 200 mg, 1 x 100 mg, 1 x 50 mg,
2 x 20 mg, 1 x 10 mg, 1 x 5 mg, 2 x 2 mg, 1 x 1 mg



90° angle connection

Separators

The separators have been specifically designed for measuring instruments, which should not come into contact with the medium of the deadweight tester or to protect against contamination of the pressure balance from the test items.



Set of trim masses M1 / F1

Connector for test items with back connection

For test items with back connection mounting, a 90° angle connection is available



Separator (without diaphragm), max. 1000 bar



Set of adapters

Set of adapters for test item connection

As a standard, the pressure balance is equipped with a quick connector for connecting the test item. For this purpose, various threaded adapters, which can be easily changed, are available. Additionally the sets of adapters include spare-O-rings and a spanner with SW32 flats and SW14 flats, for changing the adapters.

Order-Code	Description / Execution
LDW-FMS-F1	Trimm-masses (1 mg up to 50 g), class F1
LDW-FMS-M1	Trimm-masses (1 mg up to 50 g), class M1
CPB5000-ADS	Set of adapters for test item, in a case, with threaded inserts 1/4" BSP, 3/8", BSP, 1/2" NPT 1/4" NPT and M20 x 1.5 for fitting to the knurled nut of the test item connection
CPB5000-ADS-NPT	Set of adapters for test item, in a case, with threaded inserts 1/8" NPT, 1/4" NPT, 3/8" NPT and 1/2" NPT for fitting to the knurled nut of the test item connection
CPB5000-WA90	Angle connection 90°, for test items with back mounting connection
CPB5000-TV-1000	Purifier, max. 1000 bar Only for version with input for external pressure supply
CPB5000-R-SET	Set of o-rings consisting of 5 spare 8 x 2 and 5 spare 4 x 2.2
CPB5000-PN-RS	Cleaning set for LR-Cal LDW-P piston-cylinder systems

Further LR-Cal Deadweight Tester / Pressure Balances:

Model LR-Cal LDW-H

Hydraulic

Single Piston

Ranges from 1...120 to 2...300 bar
from 10...1.600 to 30...4.000 psi

Double Piston

Ranges from 1...60 / 10...700 bar to
1...60 / 20...1.400 bar
from 10...800 / 100...10.000 psi to
10...800 / 200...20.000 psi

Accuracy $\pm 0.015\%$ or $\pm 0.006\%$ of measured value



Model LR-Cal LDW-HK

Hydraulic (compact design)

Ranges from 1...120 to 10...1,200 bar
from 10...1,600 to 100...16,000 psi

Accuracy $\pm 0.05\%$ or $\pm 0.025\%$ of measured value



Model LR-Cal CPB5000-HP

High pressure, hydraulic

Ranges from 25...2,500 to 25...5,000 bar
from 350...40,000 to 350...70,000 psi

Accuracy $\pm 0.025\%$ or $\pm 0.02\%$ of measured value



Model LR-Cal CPB5600-DP

Differential pressure, pneumatic

Ranges from 0.03...2 to 0.4...100 bar
from 0.435...30 to 5.8...1500 psi

Differential pressure, hydraulic

Ranges from 0.2...60 to 2...1,000 bar
from 2.9...1,000 to 29...14,500 psi

Accuracy $\pm 0.015\%$ or $\pm 0.008\%$ of measured value



Архангельск (8182)63-90-72
Астана (7172)727-132
Астрахань (8512)99-46-04
Барнаул (3852)73-04-60
Белгород (4722)40-23-64
Брянск (4832)59-03-52
Владивосток (423)249-28-31
Волгоград (844)278-03-48
Вологда (8172)26-41-59
Воронеж (473)204-51-73
Екатеринбург (343)384-55-89
Иваново (4932)77-34-06

Ижевск (3412)26-03-58
Иркутск (395)279-98-46
Казань (843)206-01-48
Калининград (4012)72-03-81
Калуга (4842)92-23-67
Кемерово (3842)65-04-62
Киров (8332)68-02-04
Краснодар (861)203-40-90
Красноярск (391)204-63-61
Курск (4712)77-13-04
Липецк (4742)52-20-81

Киргизия (996)312-96-26-47

Магнитогорск (3519)55-03-13
Москва (495)268-04-70
Мурманск (8152)59-64-93
Набережные Челны (8552)20-53-41
Нижний Новгород (831)429-08-12
Новокузнецк (3843)20-46-81
Новосибирск (383)227-86-73
Омск (3812)21-46-40
Орел (4862)44-53-42
Оренбург (3532)37-68-04
Пенза (8412)22-31-16

Россия (495)268-04-70

Пермь (342)205-81-47
Ростов-на-Дону (863)308-18-15
Рязань (4912)46-61-64
Самара (846)206-03-16
Санкт-Петербург (812)309-46-40
Саратов (845)249-38-78
Севастополь (8692)22-31-93
Симферополь (3652)67-13-56
Смоленск (4812)29-41-54
Сочи (862)225-72-31
Ставрополь (8652)20-65-13

Казахстан (772)734-952-31

Сургут (3462)77-98-35
Тверь (4822)63-31-35
Томск (3822)98-41-53
Тула (4872)74-02-29
Тюмень (3452)66-21-18
Ульяновск (8422)24-23-59
Уфа (347)229-48-12
Хабаровск (4212)92-98-04
Челябинск (351)202-03-61
Череповец (8202)49-02-64
Ярославль (4852)69-52-93